



# AQUA/LAMP® SPECTRUM LED MULTICOLOURED UNDERWATER POOL LIGHT

## INSTALLATION/OWNER'S MANUAL



### WARNING

**Risk of Electrical Shock or Electrocutation.** This underwater light must be installed by a licensed or certified electrician or a qualified pool technician in accordance with the National Electrical Code (Canadian Electrical Code, in Canada) and all applicable codes and ordinances. Improper installation will create an electrical hazard, which could result in death or serious injury to pool or spa users, installers or others due to electrical shock, and may also cause damage to property.

Always disconnect the power to the light at the circuit breaker before installing or servicing the light. Failure to do so could result in death or serious injury to the technician, pool or spa users or others due to electrical shock.

## New Pool Installation of **AQUA/LAMP® SPECTRUM** Underwater Pool Light

1. Bond our **AQUA SLACKER (AQSL)** cable reservoir box (designed for storage of cable slack) to the back of a standard 1-1/2" return fitting. (See Figure 1.)  
The **AQSL** cable reservoir box is designed to allow for 18" - 24" inches of cable slack required for winterization and eventual lamp replacement.

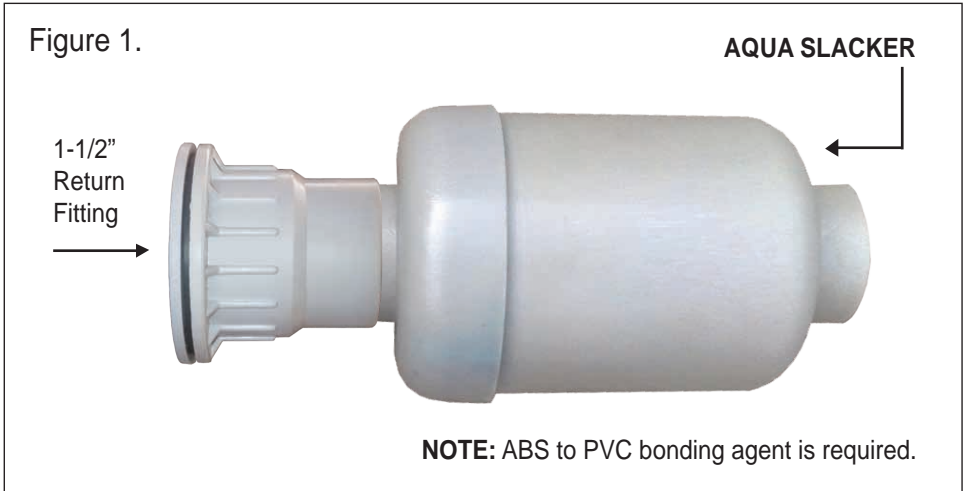

2. Thread the **AQUA/LAMP® SPECTRUM** Adapter Ring into standard 1-1/2" return fitting. Hand tighten only, (NO TOOLS REQUIRED). (See Figure 2.)

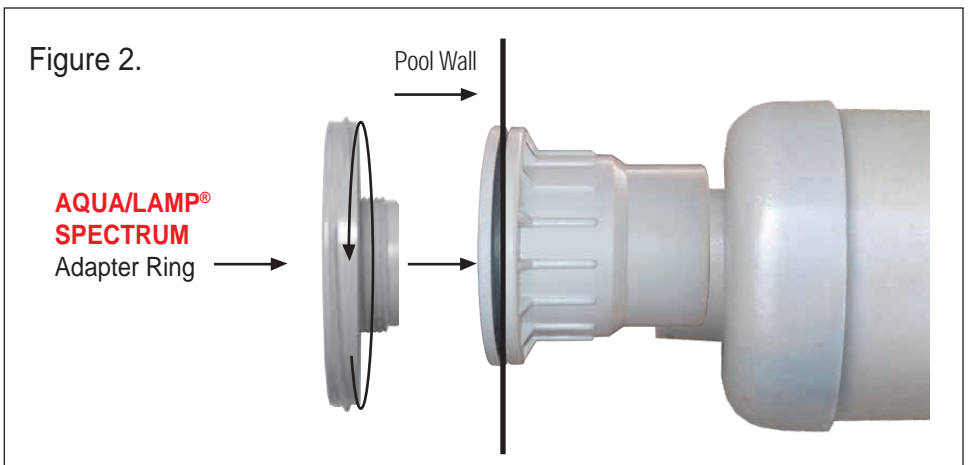

3. From the pool side, feed the loose end of the cable through the **AQUA/LAMP® SPECTRUM** Adapter Ring and then through the pool wall fitting. Then feed the cable through the **AQSL** cable reservoir box. (See Figure 3.)

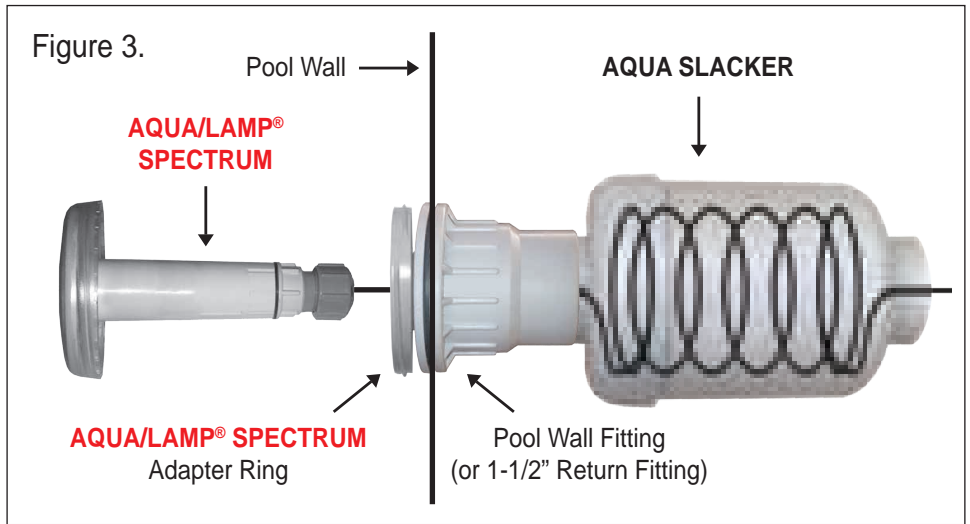

4. Continue feeding electrical cable through the conduit underground. The conduit must be attached to back of the **AQSL**. It's recommended to run the conduit above the water line, when underground, to the transformer box. (See Figure 4.) (See Winterization Pg. 7)

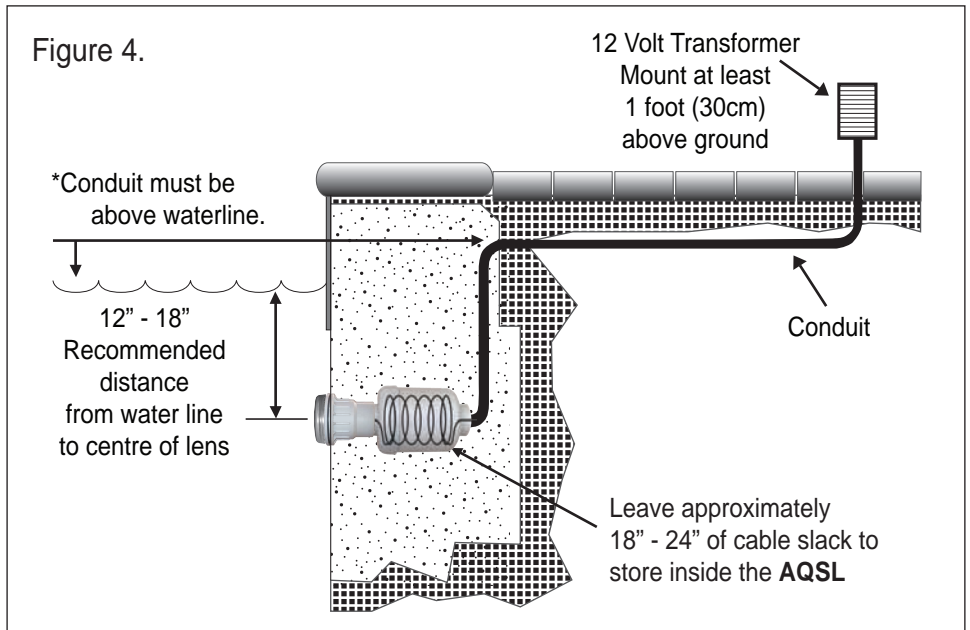

5. Complete the conduit and cable installation in accordance with the National Electrical Code (Canadian Electrical Code, in Canada) and all applicable codes and ordinances.
6. Slide **AQUA/LAMP® SPECTRUM** through the **AQUA/LAMP® SPECTRUM Adapter Ring** (attached to the standard 1-1/2" return fitting) and turn clockwise to lock into place. (See Figure 5.)

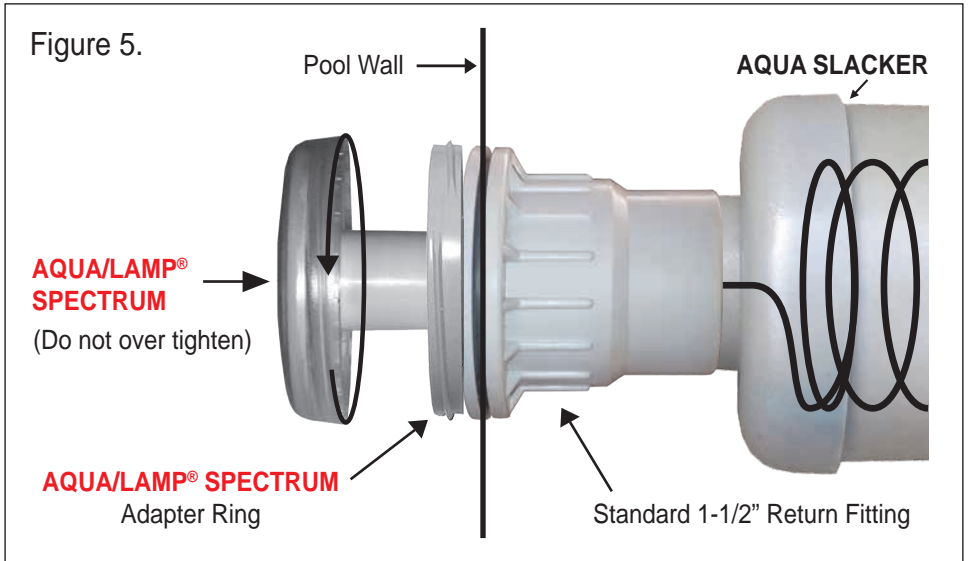

## Aqua/Lamp (AL15 & AL15-2) Transformer Box Installation

1. Select your mounting location. Holding box against the mounting surface, attach it using mounting screws through the holes provided in brackets of the transformer box.
2. Remove the cover from transformer box. Take end of the cable and pass through connector attached to box. Join end of cable around screws in transformer box, using the washers and nuts provided. Reattach transformer box cover.

# Important Aqua/Lamp Transformer Box Safety Instructions

Single/Double Models (AL15/AL15-2)

## 1) Ground Fault:

- a) **CAUTION:** Supply circuit must be protected by a ground fault circuit interrupter (G.F.C.I).
- b) **CAUTION:** Do not use extension cord set. Test ground fault circuit interrupter regularly.
- c) **CAUTION:** The GFCI is designed to protect persons from line-to-ground shock hazards which could occur in equipment operating from it. It does not prevent electric shock, but does limit the time of exposure to a period considered safe for normally healthy persons. Persons with heart problems or other conditions which make them susceptible to electric shock may still be injured by ground faults in equipment protected by this GFCI.

## 2) Fuses

- a) **CAUTION:** Replace only with same type 10amp, 250Volt fuse.

## 3) Power Supply

- a) **CAUTION:** Use copper conductors only. Do not connect two or more power supplies in parallel. Risk of electric shock. Not to be installed within 6 feet of reach of path of water.

## 4) Transformer Complete

- a) **CAUTION:** For outdoor use only. Mount at least 1 foot (30cm) above ground. Do not use with dimmers.

# Controlling Light and Choosing Lighting Effects

Aqua/Lamp Spectrum are pre-programmed with an assortment of lighting effects. When you turn the LED light off and then on again within 1-2 seconds it advances to the next effect. Effects can be controlled by either using the pool's pre-existing light switch, or by installing the Aqua/Lamp Wireless Remote Control Unit (AL20) or with any other controlling device on the market.

# Aqua/Lamp Spectrum Colour Selection

## Description of Effects (8)

- Spectrum Colour Select ..... White, Blue, Green, Pink, Turquoise
- Spectrum Transition ..... All colours transition slowly through a spectrum of colours.
- Spectrum Blue/Green Transition ..... Blue, Green transition
- Spectrum Flash ..... Strobe, All-colours

# ONE OR MORE LIGHT SYSTEMS

When you turn the Aqua/Lamp Spectrum LED off and leave it off for longer than 10 seconds or more it will reset itself and start back at the colour white. If you have one or more light systems and the lights go out of colour synchronization, turn them off for 10 seconds and they will reset to white.

**Note:** If in Spectrum flash (strobe) mode using 2 or more lights, colours will not be synchronized. When using the Aqua/Lamp Wireless Remote Control Unit (AL20), we recommend mounting at a minimum distance 4' from lights to reduce interference.

# Replacing the Aqua/Lamp Spectrum Light

Light assembly to be opened only above water level in dry surroundings.

1. Remove **AQUA/LAMP® SPECTRUM** light assembly from wall adapter by turning counter clockwise. Raise light assembly to deck. **(See Figure 6.)**
2. Turn white nut on the back of the **AQUA/LAMP® SPECTRUM** light counter clockwise **(See Figure 6.)**, until the wire terminals are exposed. **(See Figure 7.)**
3. Disconnect terminals (by pulling gently).
4. Remove old **AQUA/LAMP® SPECTRUM** light and black o-ring (on white nut). **(See Figure 7.)** Replace with new light and o-ring.
5. Reattach the terminals.
6. Thread white nut clockwise back onto the new **AQUA/LAMP® SPECTRUM** light.
7. Thread new **AQUA/LAMP® SPECTRUM** light back into pool wall.

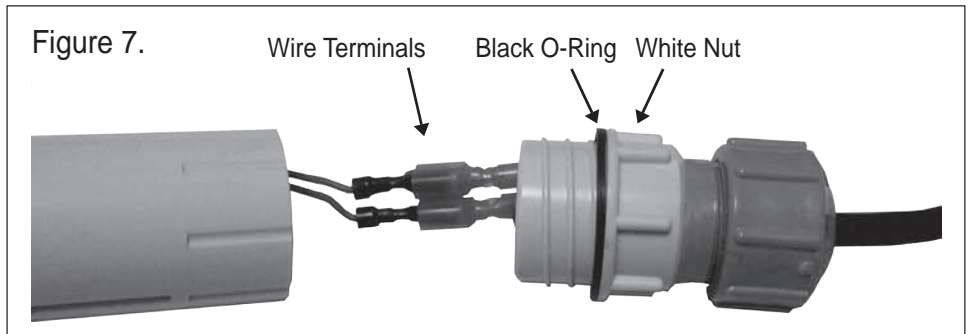
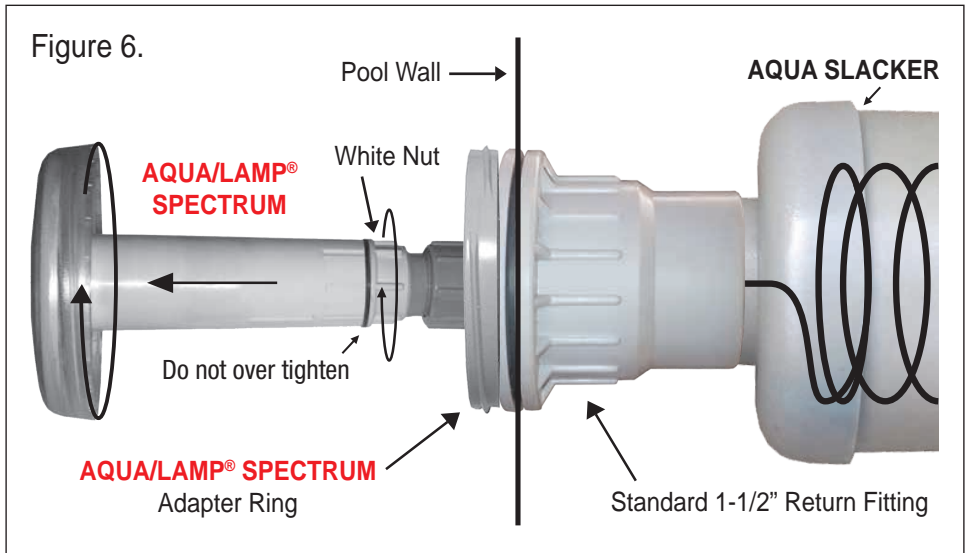

## Winterization

For off-season or winter shut-down the pool light(s) should be turned “off”.

If you do not lower your pool water level during the winter months the

**AQUA/LAMP® SPECTRUM** light should be unlocked and

- (i) weighted so it hangs below the expected ice surface or
- (ii) wrapped in a protective covering and placed under your winter cover on the pool deck.

### NOTE:

- **If water is left in conduit, damage may occur from freeze expansion. Do not seal end of conduit to allow for ice expansion in winter.**
  - Always disconnect power to the pool light before providing any service.
- 
- 

## Warranty

**AQUA/LAMP® SPECTRUM** is guaranteed for a period of **2 YEARS** from the date of its purchase against any manufacturing defects. Tampering with the unit and/or excessive physical abuse to any component of the **AQUA/LAMP® SPECTRUM** invalidates the warranty.

Any warranty claim must be pre-authorized by Consolidated Pool & Spa Industries Inc. Any defective unit shall be returned freight prepaid only. Consolidated Pool & Spa Industries Inc. will not be responsible for service/labour charges.

---

---



361 Rowntree Dairy Road, Unit 4  
Woodbridge, ON  
Canada L4L 8H1

Tel: 905.264.6496

Fax: 905.264.6508

Email: [info@consolidatedpool.com](mailto:info@consolidatedpool.com)